

▶ Measuring resistor with the Pt100-sensor referring to DIN EN 60751, Cl. B

Winding temperature monitoring and surface temperature measuring with the Pt100-Sensor

Pt100, Pt500, Pt1000

Platinum sensor probe

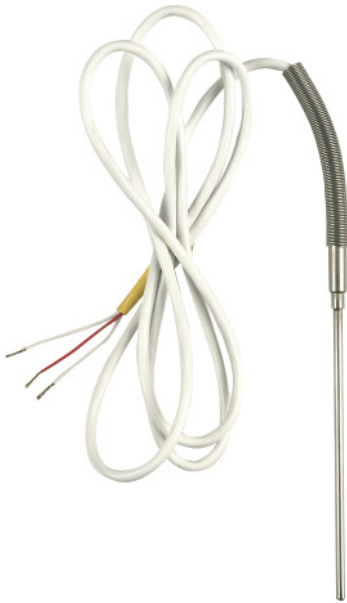

Basic information

The Pt100-sensor is used for precise temperature monitoring applications, where errors in measurement have to be excluded. The linear relationship of the resistor to temperature, simplifies its use in many electronic applications.

The precision of the Pt100 allows its universal use for temperature monitoring, control, and switching in windings, bearings, machines, motors, transformers and many other industrial applications.

Application

Temperature control of bearings, conductor-rails, machine parts and windings.

General function

The Pt100-sensor is a temperature dependent component. The resistance of the Pt100-sensor rises linearly with the temperature.

Advantages

- Very precise measuring: measuring temperature $\pm 0.5^{\circ}\text{C}$.
- Precise linear temperature-resistance characteristic.
- Low weight.
- Short response time.

Pt100-screw-in-sensor and surface sensor

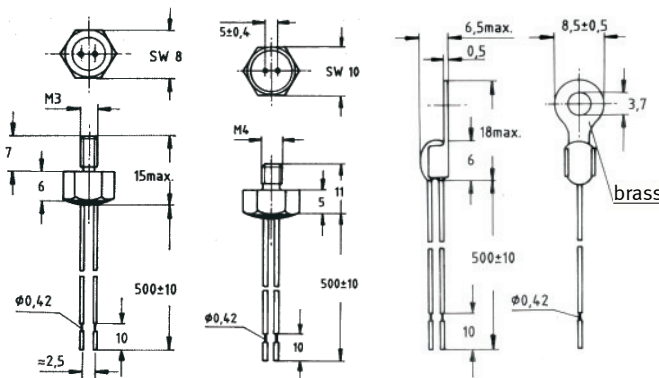

▶ Measuring resistor with the Pt100-sensor; referring to DIN EN 60751, Cl. B

Winding temperature monitoring and surface temperature measuring with the Pt100-sensor

Pt100, Pt500, Pt1000

Technical Data

Electrical Data:

Nominal resistance:	100 Ω at 0°C (Pt 100)
Basic thermistor values:	for platinum measuring resistors as in chart
Measuring range:	-50°C to +230°C, other ranges on request
Measuring current:	max. 1mA (no self-heating!)
Circuit:	standard: 2-wire, on request: 3-wire or 4-wire circuit
Insulation strength:	2.5 kV, on request up to 8 kV

Mechanical Data

Type:	Pt-sensor for surface measuring	Pt-sensor for winding monitoring
	Alu-housing screw-in sensor SW 10/M4 ring shaped cable eye for self-tapping sheet metal screw	e.g.: electric motors, transformers: in stabilised shrink tube design
Lead-in:	AWG 24, Cu-strand silvered, Teflon insulation, (optional: AWG 26, Cu-strand silvered, Teflon insulation) Standard colour: red/black, Standard length: 500mm \pm 1%	
Insulation Class:	H	
Remarks:	Special designs for liquid or gaseous media, in V2A or other materials are manufactured on request for customers specific applications and specification, also for Pt500-, Pt1000-thermistors	
Order specification:	resistor thermometer as: 2-wire-, 3-wire-, 4-wire-circuits	

▶ Measuring resistor with the Pt100-sensor; referring to DIN EN 60751, Cl. B

Winding temperature monitoring and surface temperature measuring with the Pt100-sensor

Pt100, Pt500, Pt1000

Characteristic temperature curves:

All sensors conform to DIN EN 60751:

$$-50 \dots 0^\circ\text{C}: R(t) = R(0) \cdot (1 + A \cdot t + B \cdot t^2 + C \cdot [t - 100] \cdot t^3)$$

$$0 \dots 600^\circ\text{C}: R(t) = R(0) \cdot (1 + A \cdot t + B \cdot t^2)$$

$$A = 3.90802 \cdot 10^{-3}; B = -5.802 \cdot 10^{-7}; C = -4.2735 \cdot 10^{-12}$$

R(0) = thermistor value in Ohms at 0°C

Classes:

The temperature sensors are available in the following classes:

$$1/3 \text{ DIN class B+} \quad \pm (0.10 + 0.0017 \cdot t)$$

$$1/3 \text{ DIN class B-} \quad \pm (0.10 + 0.0050 \cdot t)$$

$$\text{DIN class A} \quad \pm (0.15 + 0.0020 \cdot t)$$

$$\text{DIN class B} \quad \pm (0.30 + 0.0050 \cdot t)$$

$$2 \text{ DIN class B} \quad \pm (0.60 + 0.0050 \cdot t)$$

t = absolute value of temperature in °C

Special versions are available on request.

Permissible deviation according to DIN EN 60751:

- DIN class A
- DIN class B
- 1/3 DIN class B-
- 1/3 DIN class B+

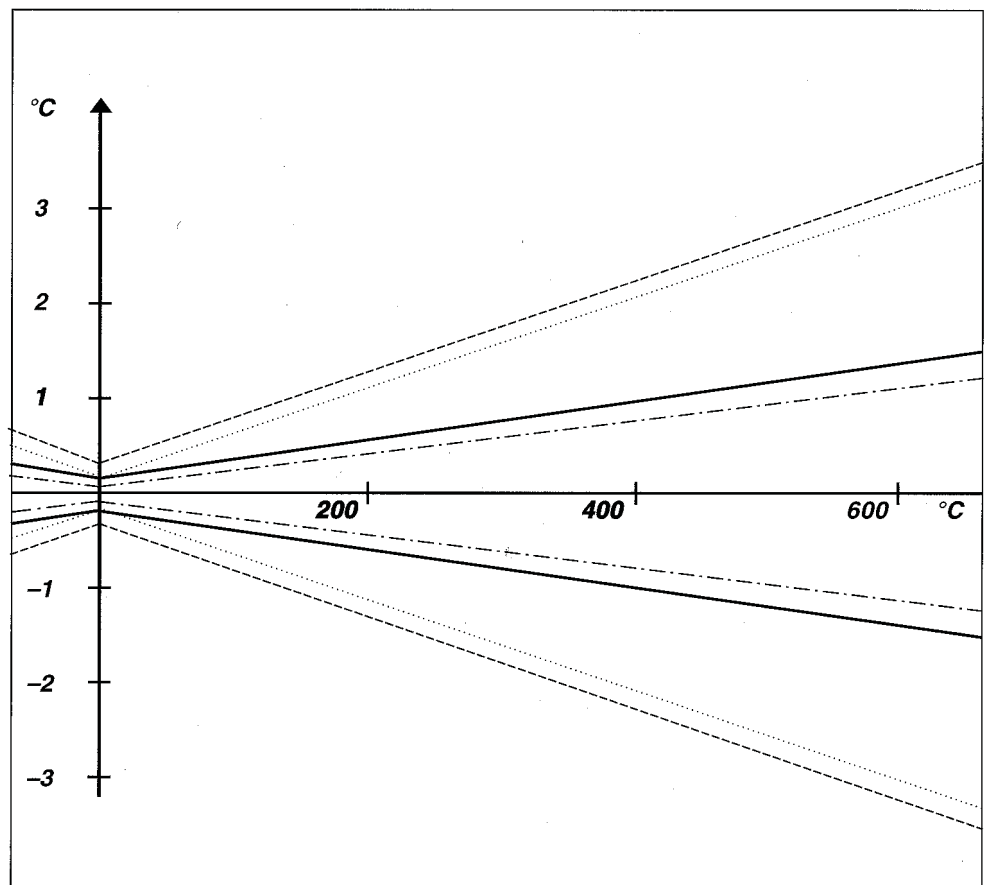

Product Information



▶ Measuring resistor with the Pt100-sensor; referring to DIN EN 60751, Cl. B

Winding temperature monitoring and surface temperature measuring with the Pt100-sensor

Pt100, Pt500, Pt1000

Resistance chart for the thermistors from -50°C to 600°C in 1°C steps. Resistance values in the chart have to be multiplied by factor 100 for Pt100, by factor 500 for Pt500, by factor 1000 for Pt1000.

°C	0	1	2	3	4	5	6	7	8	9
-50	0.803									
-40	0.843	0.839	0.835	0.831	0.827	0.823	0.819	0.815	0.811	0.807
-30	0.882	0.878	0.874	0.870	0.866	0.862	0.859	0.855	0.851	0.847
-20	0.922	0.918	0.913	0.910	0.906	0.902	0.898	0.894	0.890	0.886
-10	0.961	0.957	0.953	0.949	0.945	0.941	0.937	0.933	0.929	0.926
0	1.000	0.996	0.992	0.988	0.984	0.980	0.977	0.973	0.969	0.965
+0	1.000	1.004	1.008	1.012	1.016	1.020	1.023	1.027	1.031	1.035
10	1.039	1.043	1.047	1.051	1.055	1.058	1.062	1.066	1.070	1.074
20	1.078	1.082	1.086	1.090	1.093	1.097	1.101	1.105	1.109	1.113
30	1.117	1.121	1.124	1.128	1.132	1.136	1.140	1.144	1.148	1.152
40	1.155	1.159	1.163	1.167	1.171	1.175	1.179	1.182	1.186	1.190
50	1.194	1.198	1.202	1.205	1.209	1.213	1.217	1.221	1.225	1.229
60	1.232	1.236	1.240	1.244	1.248	1.252	1.255	1.259	1.263	1.267
70	1.271	1.275	1.278	1.282	1.286	1.290	1.294	1.297	1.301	1.305
80	1.309	1.313	1.317	1.320	1.324	1.328	1.332	1.336	1.339	1.343
90	1.347	1.351	1.355	1.358	1.362	1.366	1.370	1.374	1.377	1.381
100	1.385	1.389	1.393	1.396	1.400	1.404	1.408	1.412	1.415	1.419
110	1.423	1.427	1.430	1.434	1.438	1.442	1.446	1.449	1.453	1.457
120	1.461	1.464	1.468	1.472	1.476	1.479	1.483	1.487	1.491	1.494
130	1.498	1.502	1.506	1.501	1.513	1.517	1.521	1.525	1.528	1.532
140	1.536	1.539	1.543	1.547	1.551	1.554	1.558	1.562	1.566	1.569
150	1.573	1.577	1.581	1.584	1.588	1.592	1.596	1.599	1.603	1.607
160	1.610	1.614	1.618	1.622	1.625	1.629	1.633	1.636	1.640	1.644
170	1.648	1.651	1.655	1.659	1.662	1.666	1.670	1.674	1.677	1.681
180	1.685	1.688	1.692	1.696	1.699	1.703	1.707	1.711	1.714	1.718
190	1.722	1.725	1.729	1.733	1.736	1.740	1.744	1.747	1.751	1.755
200	1.758	1.762	1.766	1.769	1.773	1.777	1.780	1.784	1.788	1.791
210	1.795	1.799	1.802	1.806	1.810	1.813	1.817	1.821	1.824	1.828
220	1.832	1.835	1.839	1.843	1.846	1.850	1.854	1.857	1.861	1.865
230	1.868	1.872	1.875	1.879	1.883	1.886	1.890	1.894	1.897	1.901
240	1.905	1.908	1.912	1.915	1.919	1.923	1.926	1.930	1.934	1.937
250	1.941	1.944	1.948	1.952	1.955	1.959	1.962	1.966	1.970	1.973
260	1.977	1.980	1.984	1.988	1.991	1.995	1.998	2.002	2.006	2.009
270	2.013	2.016	2.020	2.024	2.027	2.031	2.034	2.038	2.042	2.045
280	2.049	2.052	2.056	2.060	2.063	2.067	2.070	2.074	2.077	2.081
290	2.085	2.088	2.092	2.095	2.099	2.102	2.106	2.110	2.113	2.117
300	2.120	2.124	2.127	2.131	2.134	2.138	2.142	2.145	2.149	2.152
310	2.156	2.159	2.163	2.166	2.170	2.173	2.177	2.181	2.184	2.188
320	2.191	2.195	2.198	2.202	2.205	2.209	2.212	2.216	2.219	2.223
330	2.226	2.230	2.234	2.237	2.241	2.244	2.248	2.251	2.255	2.258
340	2.262	2.265	2.269	2.272	2.276	2.279	2.283	2.286	2.290	2.293
350	2.297	2.300	2.304	2.307	2.311	2.314	2.318	2.321	2.325	2.328
360	2.332	2.335	2.339	2.342	2.346	2.349	2.353	2.356	2.360	2.363
370	2.367	2.370	2.373	2.377	2.380	2.384	2.387	2.391	2.394	2.398
380	2.401	2.405	2.408	2.412	2.415	2.419	2.422	2.426	2.429	2.432
390	2.436	2.439	2.443	2.446	2.449	2.453	2.457	2.460	2.463	2.467
400	2.470	2.474	2.477	2.481	2.484	2.488	2.491	2.494	2.498	2.501
410	2.505	2.508	2.512	2.515	2.518	2.522	2.525	2.529	2.532	2.536
420	2.539	2.542	2.546	2.549	2.553	2.556	2.560	2.563	2.566	2.570
430	2.573	2.577	2.580	2.583	2.587	2.590	2.594	2.597	2.600	2.604
440	2.607	2.611	2.614	2.617	2.621	2.624	2.628	2.631	2.634	2.638
450	2.641	2.645	2.648	2.651	2.655	2.658	2.661	2.665	2.668	2.672
460	2.675	2.678	2.682	2.685	2.688	2.692	2.695	2.699	2.702	2.705
470	2.709	2.712	2.715	2.719	2.722	2.725	2.729	2.732	2.735	2.739
480	2.742	2.746	2.749	2.752	2.756	2.759	2.762	2.766	2.769	2.772
490	2.776	2.779	2.782	2.786	2.789	2.792	2.796	2.799	2.802	2.806
500	2.809	2.812	2.816	2.819	2.822	2.826	2.829	2.832	2.836	2.839
510	2.842	2.845	2.849	2.852	2.855	2.859	2.862	2.865	2.869	2.872
520	2.875	2.879	2.882	2.885	2.888	2.892	2.895	2.898	2.902	2.905
530	2.908	2.912	2.915	2.918	2.921	2.925	2.928	2.931	2.935	2.938
540	2.941	2.944	2.948	2.951	2.954	2.958	2.961	2.964	2.967	2.971
550	2.974	2.977	2.980	2.984	2.987	2.990	2.993	2.997	3.000	3.003
560	3.007	3.010	3.013	3.016	3.020	3.023	3.026	3.029	3.033	3.036
570	3.039	3.042	3.046	3.049	3.052	3.055	3.059	3.062	3.065	3.068
580	3.071	3.075	3.078	3.081	3.084	3.088	3.091	3.094	3.097	3.101
590	3.104	3.107	3.110	3.113	3.117	3.120	3.123	3.126	3.130	3.133
600	3.136									

▶ Measuring resistor with the Pt100-sensor; referring to DIN EN 60751, Cl. B

Winding temperature monitoring and surface temperature measuring with the Pt100-sensor

Pt100, Pt500, Pt1000

Pt100 Typical circuits:

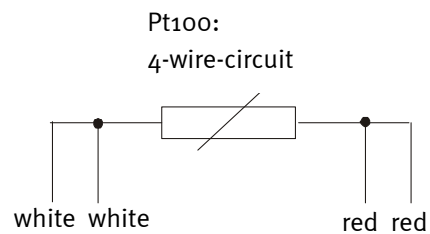
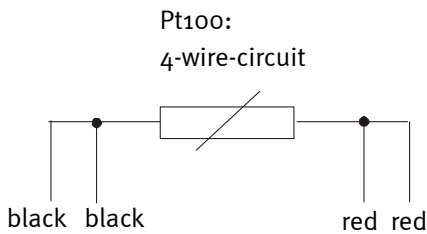
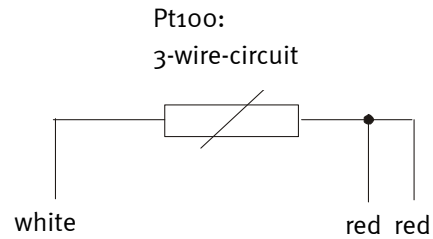
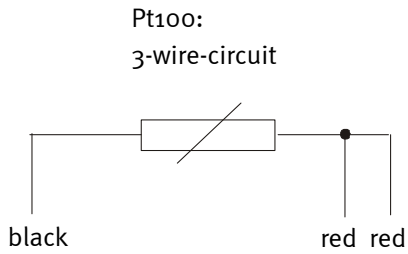
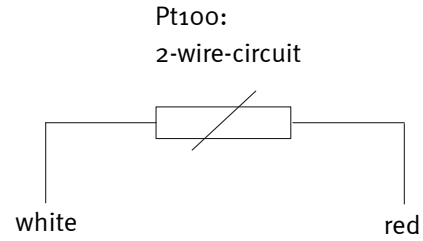
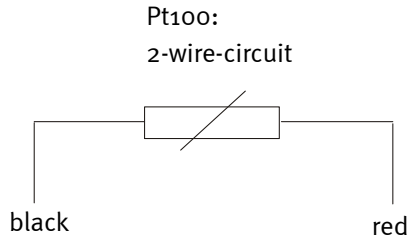

Product Information

▶ Measuring resistor with the Pt100-sensor; referring to DIN EN 60751, Cl. B

Winding temperature monitoring and surface temperature measuring with the Pt100-sensor

Pt100, Pt500, Pt1000

Pt-sensors:

Examples of Pt-thermistor-housings

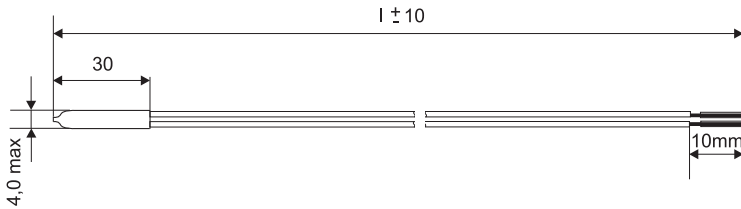

shrink tube housing for monitoring windings

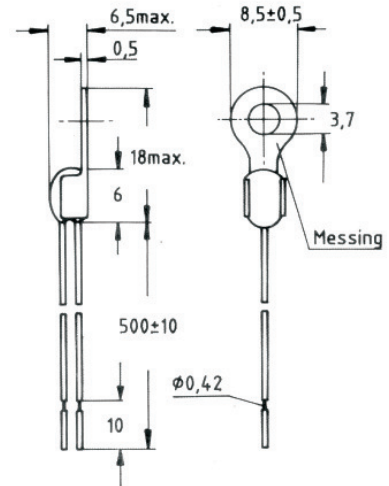

Pt-sensor in cable shoe - surface sensor

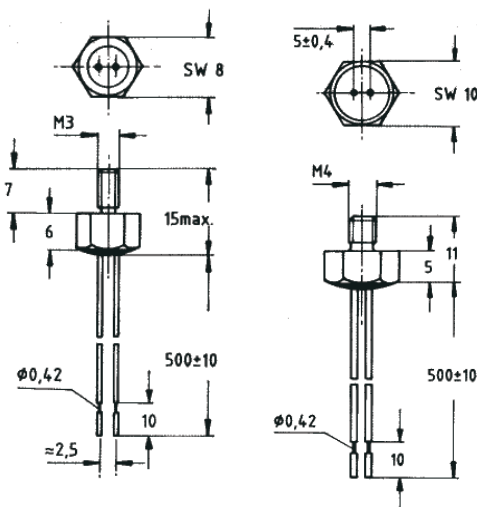

Screw-in sensors in alu-housing
SW8-M3 SW10-M4

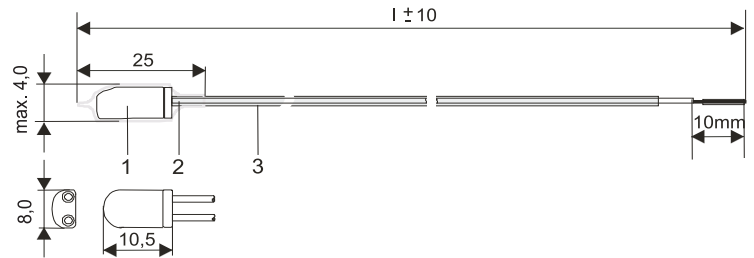

- 1 = Pt-sensor, insulated twice, in stainless steel or PPS-housing
- 2 = Terminal: stranded silver copper wire insulated with Teflon (PTFE), AWG 24 or AWG 26, according to the manufacturers choice; optional: AWG 20 or other sizes
- 3 = additional shrink tube (optional)

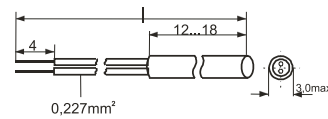

Pt-sensor in ceramics- or brass-housing

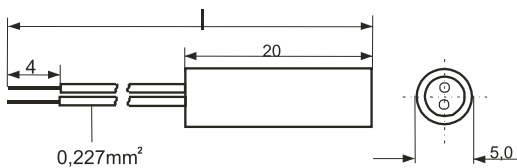

Pt-sensor in stainless steel

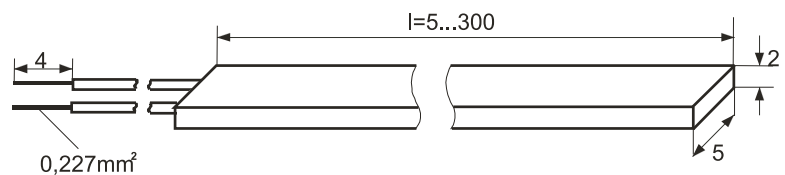

HGW-slot sensor